

REVISIONS			
REV.	DESCRIPTION	DATE	APPROVED
-	NEW RELEASE	-	-
1	MOUNTING BRACKET WAS FABRICATED NOW PURCHASED, REPLACED COMPRESSION PLATE WITH 2 PLATE WASHERS.	4/23/2026	F. BRYANT

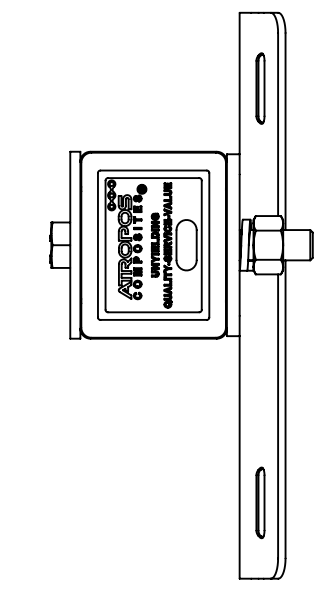
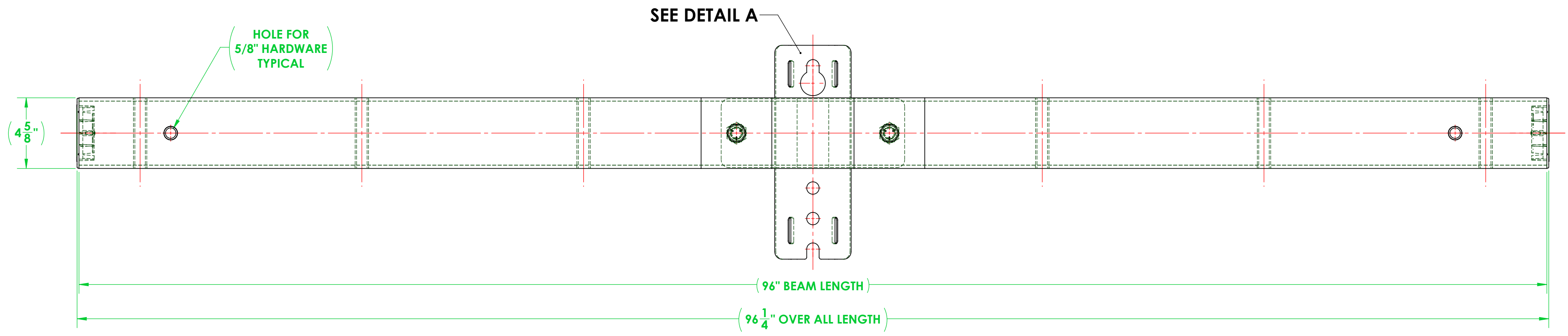
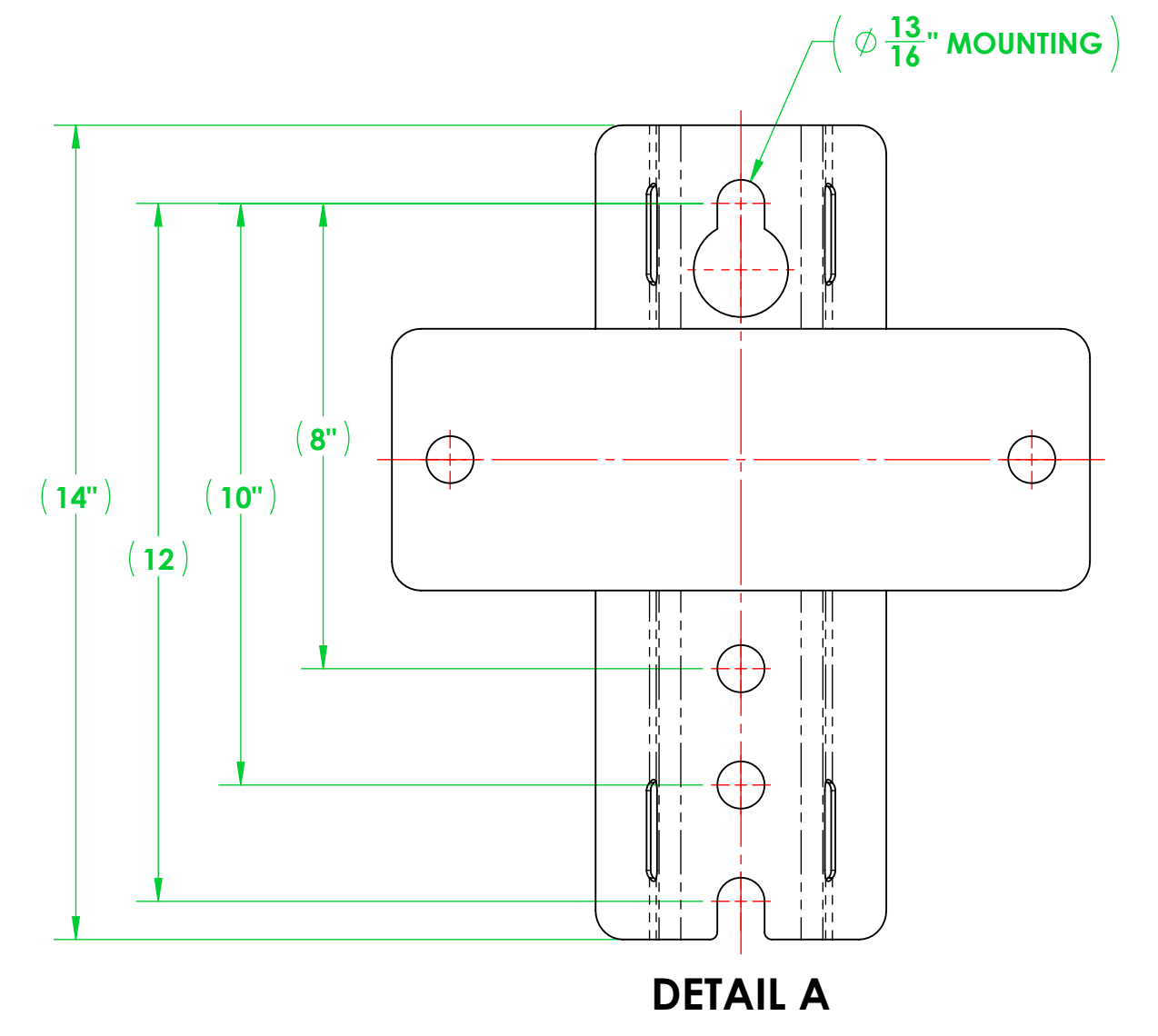
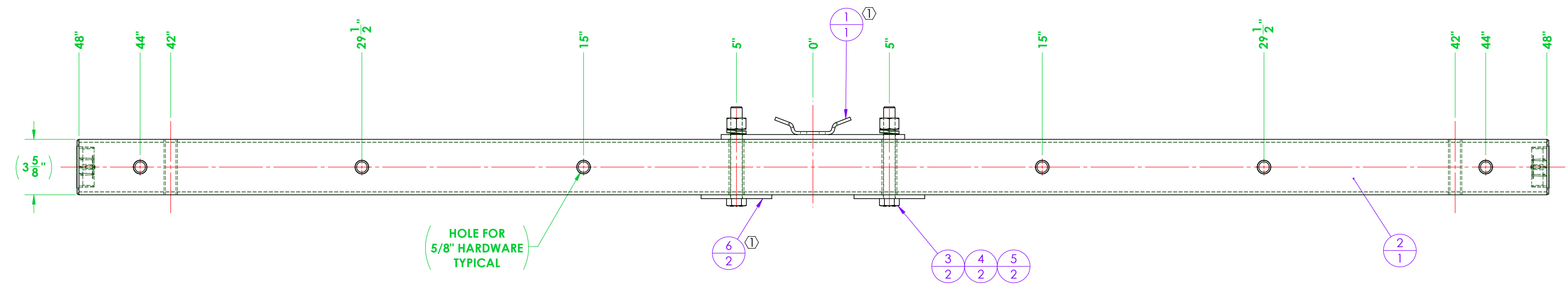

ITEM NO.	PART NUMBER	DESCRIPTION	QTY.
1	A700-0042	CROSSARM MOUNTING BRACKET, TANGENT, 3400 SERIES	1
2	3401A096-T011-X902 CA	ASSEMBLY, RUS, 3401, CROSSARM, TANGENT, 8 FT, AMERMEN	1
3	A616-0020-02	BOLT, HEX, 3/4"-10 X 6.00" LONG, HOT DIPPED GALVANIZED STEEL, 1-1/8" DRIVE	2
4	A616-0042-01	LOCK WASHER, FOR 3/4" SCREW, 0.766" ID, 1.265" OD, 0.188" THICK, HOT-DIPPED GALVANIZED STEEL	2
5	A616-0019-02	EXTREME STRENGTH NUT, HEX, 3/4"-10, 2H, HOT-DIPPED GALVANIZED	2
6	A700-0047	WASHER, SQUARE, 4.625" X 4.625" X 0.25 THICK WITH 0.81 THRU HOLE	2

GENERAL NOTES		UNLESS OTHERWISE SPECIFIED		NAME	DATE
DIMENSIONS ARE IN INCHES		STANDARD TOLERANCES		DRAWN	F. BRYANT 10/13/2025
FRACTIONAL: ±1/32		ANGULAR: ±0.5° BEND: ±2°		CHECKED	TJS 10/21/2025
MACHINED: ±0.005		TWO PLACE DECIMAL: ±0.03		ENG APPR.	
THREE PLACE DECIMAL: ±0.005		INTERFERE GEOMETRIC TOLERANCING PER ANSI Y14.5		MFG APPR.	
MATERIAL		PROPERTY AND CONFIDENTIAL		Q.A.	
FINISH		THE INFORMATION CONTAINED IN THIS DRAWING IS THE SOLE PROPERTY OF VETURIO. ANY REPRODUCTION IN PART OR AS A WHOLE WITHOUT THE WRITTEN PERMISSION OF VETURIO IS PROHIBITED.			
DO NOT SCALE DRAWING		SCALE: 1:8		WEIGHT: 48.72	

12208 MISSOURI BOTTOM ROAD, HAZELWOOD, MO 63042
PHONE: 314.714.4001 FAX: 314.895.1943
SALES@LABYRINTH-TECH.COM

TITLE:
ASSEMBLY, TANGENT, 3401, (6) WIRE, 8 FT.

SIZE DWG. NO. REV
D 3401A096-T011-X902 1

SHEET 1 OF 1